

Operating instructions

Room climate sensor Standard
Art. no. 2004 ..

Room climate sensor Komfort
Art. no. 2005 ..

Table of contents

| | | |
|-----------|---|-----------|
| 1 | Safety instructions | 3 |
| 2 | Device components | 3 |
| 2.1 | Front view | 3 |
| 2.2 | Rear view | 4 |
| 2.3 | Icons of the operating element..... | 5 |
| 2.4 | Icons in the display | 6 |
| 3 | System information | 7 |
| 4 | Intended use | 8 |
| 5 | Product characteristics | 9 |
| 6 | Mounting and electrical connection | 10 |
| 6.1 | Mounting and connecting the device | 10 |
| 6.2 | Dismantling | 14 |
| 7 | Commissioning | 15 |
| 7.1 | Safe-state mode..... | 16 |
| 7.2 | Master reset | 16 |
| 8 | Operation | 18 |
| 8.1 | Examples for operating various standard applications | 19 |
| 9 | Technical data | 22 |
| 9.1 | Product information in accordance with the Ecodesign Directive (ErP 2009/125/EC)..... | 24 |
| 9.1.1 | Ecodesign Table 6..... | 24 |
| 9.1.2 | Ecodesign Table 7..... | 25 |
| 10 | Accessories | 26 |
| 11 | Warranty | 27 |

1 Safety instructions



Electrical devices may be mounted and connected only by electrically skilled persons.

To avoid potential damage, read and follow the following instructions:

Danger of electric shock. During installation and cable routing, comply with the regulations and standards which apply for SELV circuits.

Instructions are part of the product. So keep them in a safe place.



The technical documentation on our web site contains detailed information.

2 Device components

2.1 Front view

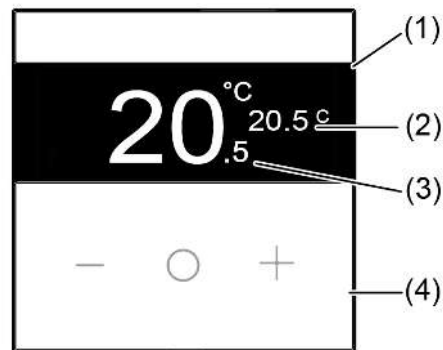

Figure 1: Front view

- (1) Display
- (2) Target temperature / humidity
- (3) Actual-temperature
- (4) Operating element (operating buttons 1 - 3)

2.2 Rear view

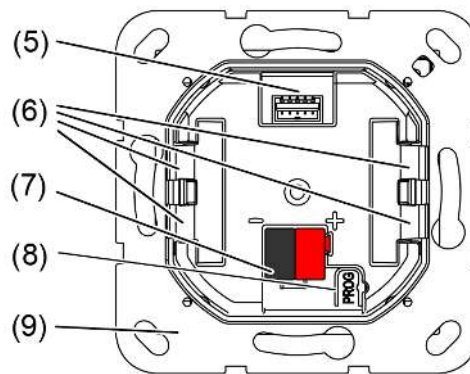

Figure 2: Rear view

- (5) Device connection terminal for remote sensor / extensions (only "Comfort" variant)
- (6) Retaining clips for device fixation at the supporting frame
- (7) Device connection terminal, bus
- (8) Programming button with programming LED
- (9) Supporting frame

2.3 Icons of the operating element

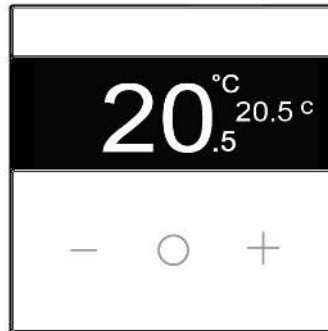

Figure 3: Icons of the operating element



Pressing the button leads to an increase in the setpoint value.



Pressing the button leads to a reduction in the setpoint value.













ON / OFF: The device is switched on/off with a long press of the button.

Change operating mode and display of measured values: A short press of the button switches between the operating modes and the display of measured values.

2.4 Icons in the display



Figure 4: Icons in the display

-  Comfort operating mode is active
-  Reduction temperature operating mode is active
-  Night setback operating mode is active
-  Eco operating mode is active
-  Operating lock is activated
-  Air humidity
-  Heating/cooling
-  The boost function is active
-  Window status (open window was recognised)
-  Air quality status (VOC, VOC (IAQ), eCO₂); (only for "Comfort" variant)
 Green = good
 Yellow = medium
 Red = bad

3 System information

This device is a product of the KNX system and complies with the KNX directives. Detailed technical knowledge obtained in KNX training courses is a prerequisite for proper understanding.

The function of the device depends on the software. Detailed information on software versions and the respective scope of functions as well as the software itself can be obtained from the manufacturer's product database.

The device can be updated. Firmware can be easily updated with the Gira ETS Service App (additional software).

The device is KNX Data Secure capable. KNX Data Secure offers protection against manipulation in building automation and can be configured in the ETS project. Detailed technical knowledge is a prerequisite. A device certificate, which is attached to the device, is required for safe commissioning. During mounting, the device certificate must be removed from the device and stored securely.

Planning, installation and commissioning of the device are carried out with the aid of the ETS, version 5.7.7 and higher or 6.3.0.

4 Intended use

- Operation in KNX system
- Operating loads, e.g. light on/off, dimming and colour temperature control, Venetian blinds/shutters/awnings/roof windows, 1-byte values, 2-byte values, 3-byte values and 6-byte values, brightness values, temperatures, colour temperature values, retrieving and saving light scenes as scene extension units (only "Comfort" variant)
- Calling up and saving internal light scenes (only "Comfort" variant)
- Measurement and feedback control of the room temperature
- Measuring the room humidity (only "Comfort" variant)
- Measuring the air quality (only "Comfort" variant)
- Measuring the dew point temperature (only "Comfort" variant)
- Indication of an alarm (only "Comfort" variant)
- Mounting in appliance box (Ø 60 mm)

5 Product characteristics

| Product characteristic per product variant | Comfort | Standard |
|--|---------|----------|
| Via extension unit: Push-button sensor functions switching, dimming and colour temperature control, Venetian blinds/shutters/awnings/roof windows, value transmitter, scene extension unit, short and long push-button, room temperature control unit adjustable | ✓ | - |
| Controller extension with operating mode selection, forced operating mode switch over, presence function and setpoint temperature shift | ✓ | - |
| Adjustable display brightness and day and night mode | ✓ | ✓ |
| Disable or function switch-over of all or of individual button functions possible with disabling function | ✓ | ✓ |
| Scene control of up to 64 scenes with 8 scene outputs each | ✓ | - |
| Heating control for heating/cooling, floor temperature monitoring, setpoint temperature adjustment, setpoint temperature limitation and increase | ✓ | ✓ |
| Temperature measurements optionally with device internal sensor and external sensor connected via communication object | ✓ | ✓ |
| Temperature measurements optionally with device internal sensor, wired sensor to the device connection terminal and external sensor connected via communication object | ✓ | - |
| Room humidity measurement with internal device humidity sensor | ✓ | - |
| Air quality measurement with internal VOC sensor | ✓ | - |
| Measurement of the dew point temperature | ✓ | - |
| Heartbeat function | ✓ | ✓ |
| Logic functions as logic gates, converters, blocking elements, comparators or limit value switches with hysteresis | ✓ | - |
| Integrated bus coupling unit | ✓ | ✓ |

6 Mounting and electrical connection



DANGER!

Danger of electrical shock when mains voltage 230 V or other external voltages are connected!

Electric shocks can be fatal.

Device may be destroyed.

Only connect potential-free push-buttons, switches or contacts.

6.1 Mounting and connecting the device

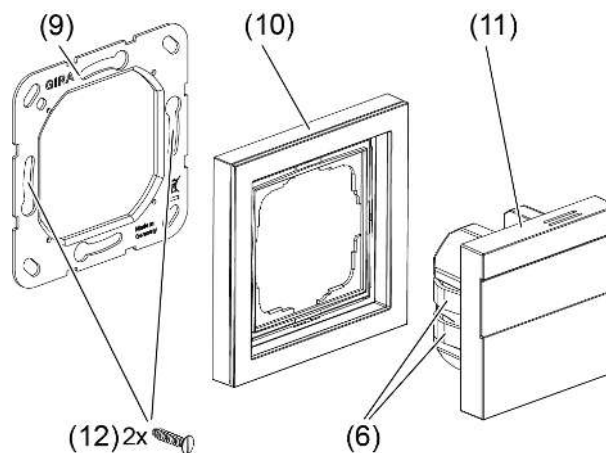

Figure 5: Mount device

- (6) Retaining clips for device fixation at the supporting frame
- (9) Supporting frame
- (10) Cover frame (accessory)
- (11) Device
- (12) Box screws

The device should be used in an air-tight appliance box. Otherwise temperature and humidity reading can be negatively influenced by draughts.

- Mounting in suitable appliance box. Observe cable routing and spacing.
- Only connect potential-free push-buttons, switches or contacts (only "Comfort" variant).
- Mount supporting frame on an appliance box.

i Note the TOP marking.

i Use the enclosed box screws.

- Connect bus line with device connection terminal observing the correct polarity (red = +, black = -).
- In secure mode: Enter or scan the device certificate and add it to the project. A high resolution camera should be used to scan the QR code.

- Optional (only "Comfort" variant) (see chapter "Accessories" ▶ Page 26): Push-buttons, switches, contacts. Connect LEDs or NTCs as shown in the connection examples using the enclosed connection cables. The connection examples (and (see figure 8)) show how to use them with inputs, outputs and sensors.
- ❗ The matching cover frame for the device must be ordered separately.
 - Fit the cover frame flush. The cover frame is fixed by the device.
 - Attach the device with cover frame onto the supporting frame.

The device can be put into operation.

- ❗ Make sure the that the retaining clips properly fit in the supporting frame.

The physical address is programmed (see chapter "Commissioning" ▶ Page 15) in the next work step.

Installation instructions (only "Comfort" variant)

- To avoid interference from EMC radiation, the cables of the inputs should not be run in parallel to cables carrying mains voltage or to load cables.
- The voltage potentials of the connecting cables for the inputs and outputs are not galvanically isolated from the bus voltage.
The connection cables effectively extend the bus line. The specification for the bus cable length (max. 1000 m) must be observed.
- Do not connect the **COM** connections of several room climate sensors together.
- Use channel 1 for NTC temperature sensors (see accessories).
- Switches, push-buttons, dew and leakage sensors can be connected to all channels.
- No series resistance required for the connection of LEDs.

When extending the enclosed cable set (see figure 6), observe the maximum cable length l : 25 cm, can be extended to max. 30 m.

The following applies: the COM cable for each cable set must not exceed the total maximum length of l .

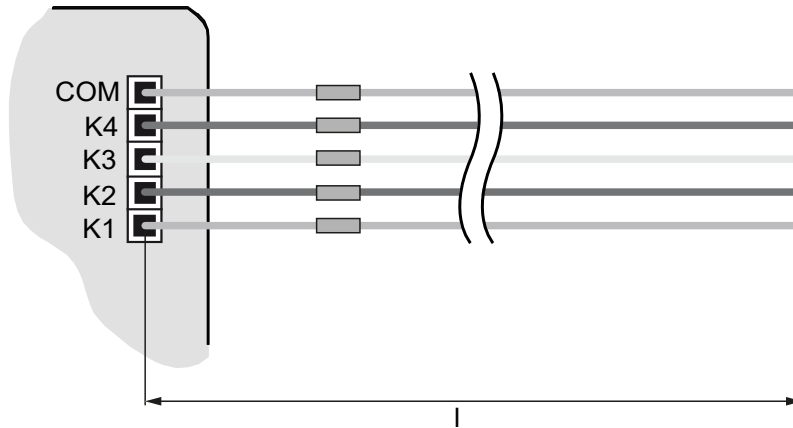

Figure 6: Maximum cable length

Connection of potential-free contacts (only "Comfort" variant)

- Connect push-buttons, switches, contacts, LEDs or NTCs as shown in the connection examples using the enclosed connection cables ((see figure 7) and (see figure 8)). The connection examples show the use with inputs, outputs and sensors.

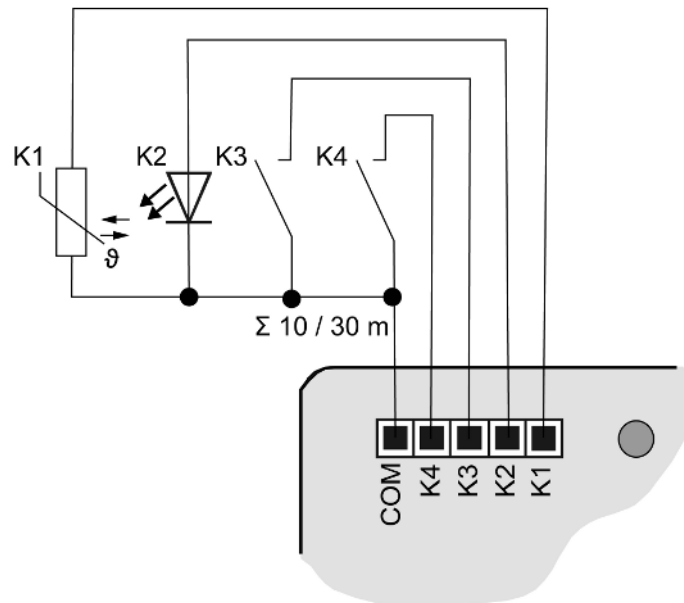

Figure 7: Connection example

It is possible to switch outputs in parallel, for loads with high energy consumption. (see figure 8) and **K1-K3** are switched in parallel in this example.

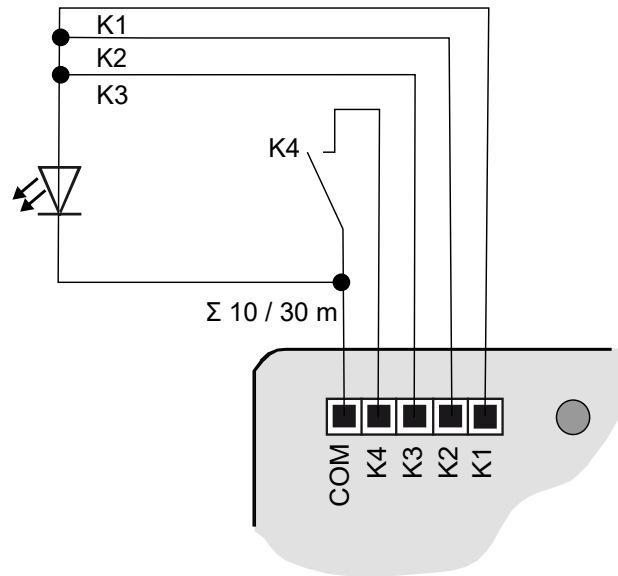

Figure 8: Connection example with outputs switched in parallel

6.2 Dismantling

- Carefully pull the device forwards together with the cover frame.

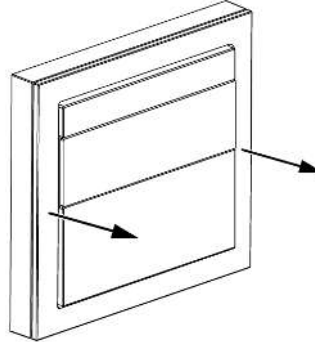

Figure 9: Dismantling the device

7 Commissioning

Programming the physical address and application program

i Project design and commissioning with ETS version 5.7.7 and higher or 6.3.0.

In secure operation (prerequisites):

- Secure commissioning has been activated in the ETS.
- Device certificate entered/scanned or added to the ETS project. A high resolution camera should be used to scan the QR code.
- Document all passwords and keep them safe.

The programming button is located on the back of the appliance (see chapter "Rear view" ▶ Page 4).

Precondition: The device is connected and ready for operation.

- Activating Programming mode: push the programming button.

The programming LED lights up red. Programming mode is activated.

- Programming the physical address.

The programming LED goes out. Physical address is programmed.

- Programming the application program.

The device is for use.

i The display can be switched off temporarily while the application program is being programmed. As soon as the programming process has been successfully completed, the device switches on.

7.1 Safe-state mode

The safe-state mode stops the execution of the loaded application program.

If the device does not work properly - for instance as a result of errors in the project design or during commissioning - the execution of the loaded application program can be halted by activating the safe-state mode. The device remains passive in safe-state mode, since the application program is not being executed (state of execution: terminated).

Only the system software of the device is still functional. ETS diagnosis functions and programming of the device are possible.

Activating safe-state mode

- Switch off the voltage.
- Press and hold down the programming button.
- Switch on voltage.

Safe-state mode is activated. The programming LED flashes slowly (approx. 1 Hz).

Release the programming button only after the programming LED starts flashing.

Deactivating safe-state mode

- Switch off the voltage or carry out ETS programming.

7.2 Master reset

The master reset restores the basic device settings (physical address 15.15.255, firmware remains in place). The device must then be recommissioned with the ETS.

- i** In secure operation: A master reset deactivates device security. The device can then be recommissioned with the device certificate.
- i** Devices can be reset to factory settings with the ETS Service App. This function uses the firmware contained in the device that was active at the time of delivery (delivery state). Restoring the factory settings causes the devices to lose their physical address and configuration.

If the device - for instance as a result of errors in the project design or during commissioning - does not work properly, the loaded application program can be deleted from the device by performing a master reset. The master reset resets the device to delivery state. Afterwards, the device can be put into operation again by programming the physical address and application program.

Performing a master reset

Precondition: The safe-state mode is activated.

- Press and hold down the programming button for > 5 seconds until the programming LED starts flashing quickly.
- Release the programming button.

The device performs a master reset. The programming LED is switched on.

The device restarts and is in delivery state.

8 Operation

- i** Touch-sensitive surfaces can be damaged. Do not operate the device with sharp or pointed objects.

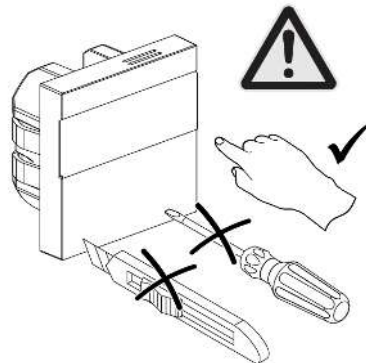

Figure 10: Damage to appliances due to sharp or pointed objects

The device is operated by pressing the buttons for a short, medium-long or long time, which depends on the specific functions configured.

| Status | Min. length of time the button is pressed | Max. length of time the button is pressed |
|-------------------------------|---|---|
| no keystroke recognised | 0 | ≤ 50 ms |
| Brief pressing of a button | > 50 ms | ≤1 s |
| Button press medium long | > 1 s | ≤4 s |
| Pressing and holding a button | > 4 s | ≤10 s |

8.1 Examples for operating various standard applications

Increasing or decreasing the target temperature

- Short press(>50 ms) of the - or + button

With every brief press of a button the setpoint temperature changes by 0.5 °C. The set value is retained in manual mode; in automatic mode it is retained until the next switching time is reached.

If no operation is performed within a previously defined period of time (1 second) or if the O button is pressed briefly, the setpoint temperature is temporarily adopted. This is signalled by the device flashing twice.

In cooling mode, the – or + buttons cannot be used to change the setpoint temperature.

If the display is switched off, it is necessary to press the - or + button a second or further time before changing the setpoint.

- Medium-long press(>1 s) of the - or + button

Each time the button is pressed for a medium length of time, the setpoint temperature changes by 0.5 °C at a faster rate. The set value is retained in manual mode; in automatic mode it is retained until the next switching time is reached.

If no operation is performed within a previously defined period of time (1 second) or if the O button is pressed briefly, the setpoint temperature is temporarily adopted. This is signalled by the device flashing twice.

- Long press(>4 s) on the - or + button

In heating mode, the stored setpoint temperature is retrieved:

– = reduction temperature

+ = comfort temperature

- i** During a detected temperature drop, changing the setpoint temperature is not possible.

Display humidity (only "Comfort" variant with activated mode)

The function is only available for appliance variants with an integrated humidity sensor. If no humidity sensor is present, there is no reaction.

- Short press(>50 ms) of the O button

When the O button is pressed briefly, the humidity is displayed last after the various modes have been run through. If no operation is performed for at least 7 seconds, the device returns to the standard view.

If the O button is pressed again briefly, the display returns to the standard view (setpoint temperature display) and the first operating mode.

If no setting has been temporarily stored, the device jumps to the state specified by the actuator.

Window detector active

If a window is recognised as open, the window symbol is displayed and operation is blocked.

- Button press of any combination or duration

When the window is open, the window symbol flashes twice to show that the device is locked.

When the window is closed, the window symbol disappears and the operating lock is cancelled.

Display operating mode and associated setpoint temperature (only "Comfort" variant)

- Short press(>50 ms) of the O button

A short press of the O button displays and applies the next operating mode and the associated setpoint temperature.

When the last operating mode has been reached, the humidity is displayed the next time the button is pressed.

- Briefly press the O button within a defined period of time

A short press of the button switches to the heating / cooling / eco operating mode.

Activating the operating lock

- Simultaneous medium-long(>1 s) press of the – and + buttons

Pressing both buttons for a medium length of time activates the operating lock and the lock symbol appears on the display. The lock symbol flashes twice to show that the device has been locked.

If both buttons are pressed again for a medium length of time, the lock symbol disappears and the operating lock is cancelled.

Switch off display

- Long press(>4 s) of the O button

If you press and hold the O button, the device displays OFF for 3 seconds and then switches off the display.

If the O button is pressed and held again, the device switches back to the initial state (as specified by the actuator).

Activating the boost function

With the boost function, the output is switched on for a maximum of 5 minutes without temperature control action in order to obtain a temporary increase in temperature.

i The boost function can be activated only in heating mode and if no temperature drop has been detected.

- Simultaneous medium-long(>1 s) press of the – and O buttons

The boost function is active. The display counts down from 300 seconds and then switches back to normal mode.

To end the boost function prematurely, press the - and O buttons simultaneously for a medium length of time(>1 s).

9 Technical data**Ambient conditions**

Ambient temperature -5 ... +45 °C

Storage/transport temperature -20 ... +70 °C

Relative humidity 5 ... 95% (no moisture condensation)

Protection class III

Installation dimensions (see figure 11)

Construction height A = 10 mm

Installation depth B = 19 mm

KNX

KNX medium TP256

KNX commissioning mode S mode

Rated voltage DC 24 ... 30 V SELV

Current consumption KNX 8 ... 14 mA

Connection mode KNX Standard device connection terminal

Connecting cable KNX EIB-Y (St)Y 2x2x0.8

Information according to ErP 2009/125/EC

Electronic room temperature controller Yes

Power consumption

– In networked standby mode < 0.5 W

– In standby mode with information or status indication Yes

Control accuracy yes (0.5 K)

This controller fulfils the following control functions HP(1/2/3/0/0/0/0/8)

Inputs for potential-free contacts (only "Comfort" variant)

Number of inputs 4

(K1 can be used for NTC temperature sensors)

Output voltage DC 5 V SELV

Output current max. 3.2 mA

LED current 2.2 mA per output

Connection of channels 5-core wiring harness

Connection cable for remote sensor, condensation and leakage sensor, extensions (see accessories)

Cable type extension NYM-J 3×1.5 or J-Y(St)Y 2×2×0.8

Length, wiring harness 25 cm, can be extended to max. 30 m

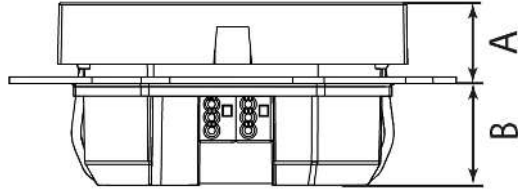

Figure 11: Installation dimensions

9.1 Product information in accordance with the Ecodesign Directive (ErP 2009/125/EC)

9.1.1 Ecodesign Table 6

| Contact details: Gira Giersiepen GmbH & Co. KG, Dahlienstraße, 42477 Radevormwald, Germany | | | |
|--|------------|-------------|------|
| Model identifier: Room climate sensor Standard, 2004 .. Room climate sensor Komfort, 2005 .. | | | |
| Specification | Icon | Value | Unit |
| Power consumption | | | |
| In the off state | P_0 | - | W |
| In standby mode | P_{sm} | - | W |
| In idle state | P_{idle} | - | W |
| In networked standby mode | P_{nsm} | < 0.5 | W |
| In standby mode with information or status display | | yes | |
| Type | | | |
| Single-stage heat output, no room temperature control | | no | |
| Two or more manual levels, no room temperature control | | no | |
| Room thermostat with mechanical thermostat | | no | |
| Electronic room temperature controller | | yes | |
| Electronic room temperature controller with time-of-day control | | no | |
| Electronic room temperature controller with weekday regulation | | no | |
| Other control options | | | |
| Presence detection | | yes | |
| Detection of open windows | | yes | |
| Remote control option | | yes | |
| Adaptive control of the start of heating | | no | |
| Operating time limit | | no | |
| Black ball sensor | | no | |
| Self-learning function | | no | |
| Control accuracy | | yes (0.5 K) | |

9.1.2 Ecodesign Table 7

Codes of the control functions

The format of the code is TC (f1/f2/f3/f4/f5/f6/f7/f8), where TC is the code for temperature control and f1 to f8 are the codes for the respective control functions, if available; otherwise "0" must be specified.

| | | (TC)* | Control functions | | | | | | | | | |
|-----------------------------|---|-------|-------------------|----|----|----|----|----|----|----|---|--|
| | | | f1 | f2 | f3 | f4 | f5 | f6 | f7 | f8 | | |
| Type of temperature control | Single-stage heat output, no room temperature control | NC | | | | | | | | | | |
| | Two or more manual levels, no room temperature control | TX | | | | | | | | | | |
| | Room thermostat with mechanical thermostat | TM | | | | | | | | | | |
| | Electronic room temperature controller | HP | | | | | | | | | | |
| | Electronic room temperature controller with daytime control | TD | | | | | | | | | | |
| | Electronic room thermostat with weekday control | TW | | | | | | | | | | |
| Control functions | Presence detection | | 1 | | | | | | | | | |
| | Detection of open windows | | | 2 | | | | | | | | |
| | Remote control option | | | | 3 | | | | | | | |
| | Adaptive control of the start of heating | | | | | 4 | | | | | | |
| | Operating time limit | | | | | | 5 | | | | | |
| | Black ball sensor | | | | | | | 6 | | | | |
| | Self-learning function | | | | | | | | 7 | | | |
| | Control accuracy with CA < 2 Kelvin and CSD < 2 Kelvin | | | | | | | | | | 8 | |

* Temperature control code

10 Accessories

Accessories (only "Comfort" variant)

Remote sensor

Art. no. 1493 00

Leakage sensor

Art. no. 5068 00

Condensation sensor

Art. no. 5069 00

11 Warranty

The warranty is provided by the specialist trade in accordance with statutory requirements. Please submit or send faulty devices postage paid together with a fault description to your responsible salesperson (specialist trade / installation company / electrical specialist trade). They will forward the devices to the Gira Service Center.

Gira
Giersiepen GmbH & Co. KG
Elektro-Installations-
Systeme

Industriegebiet Mermbach
Dahlienstraße
42477 Radevormwald

Postfach 12 20
42461 Radevormwald

Deutschland

Tel +49(0)21 95 - 602-0
Fax +49(0)21 95 - 602-191

www.gira.de
info@gira.de